

# MELT Class 1 Driver Training

## *Backing Basics*

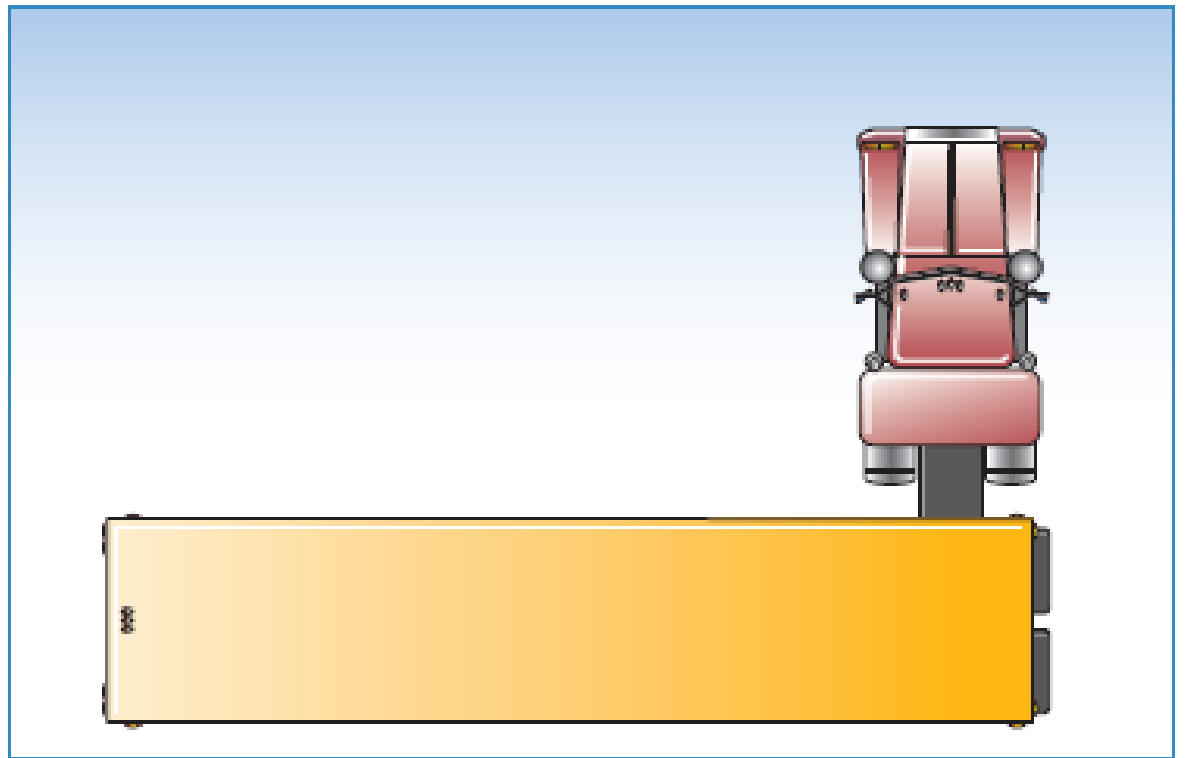

## Blind side – Sight side

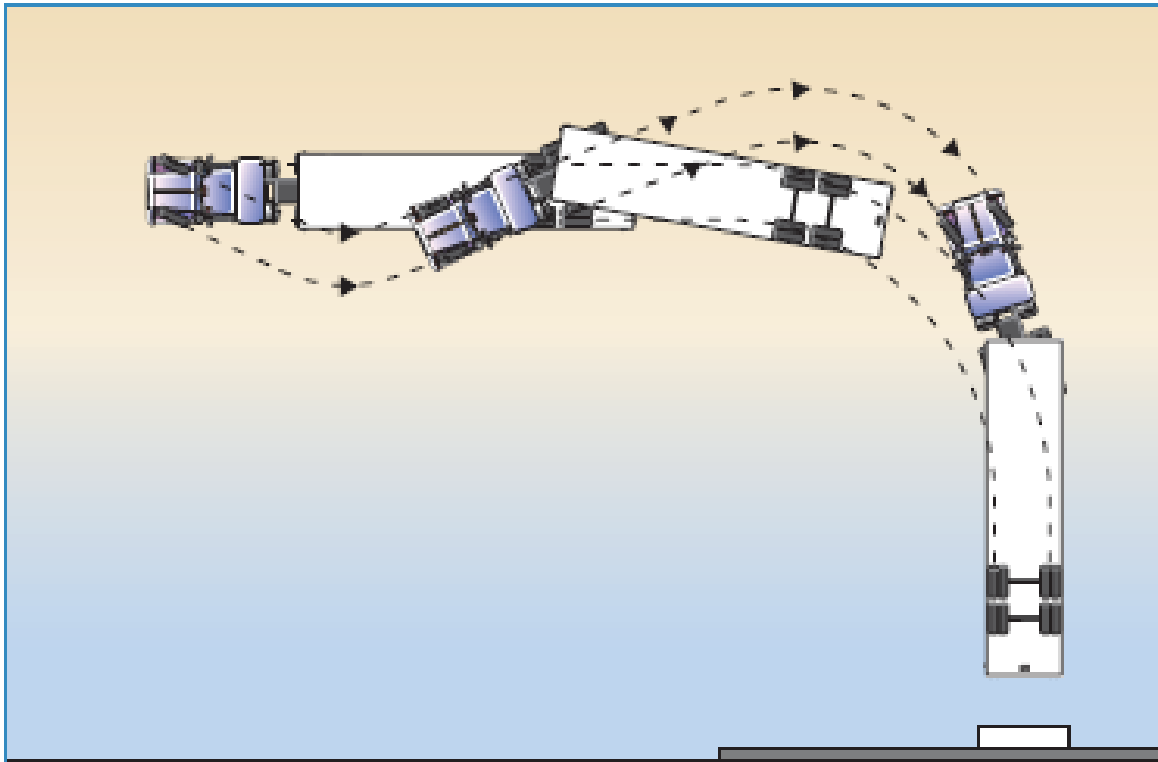
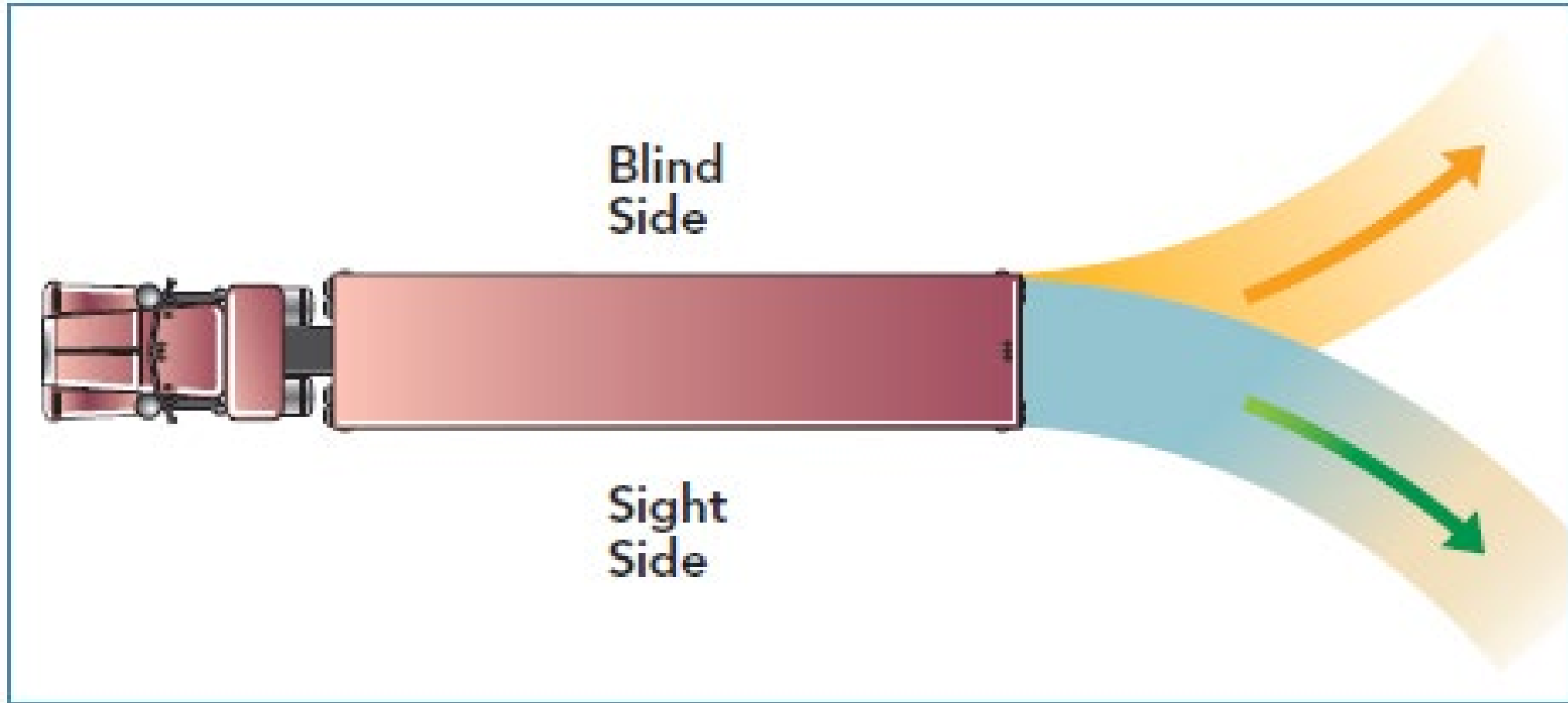

# General tips for backing

- Start in the best position
- Adjust your mirrors
- Turn on 4-way flashers
- Get out and look (GOAL)
- Silence your audio and roll down the window
- Sound horn
- Use mirrors on both sides
- Back slowly
- Don't be in a hurry
- Back and turn toward the driver's side
- Back out of traffic

# Back out of traffic

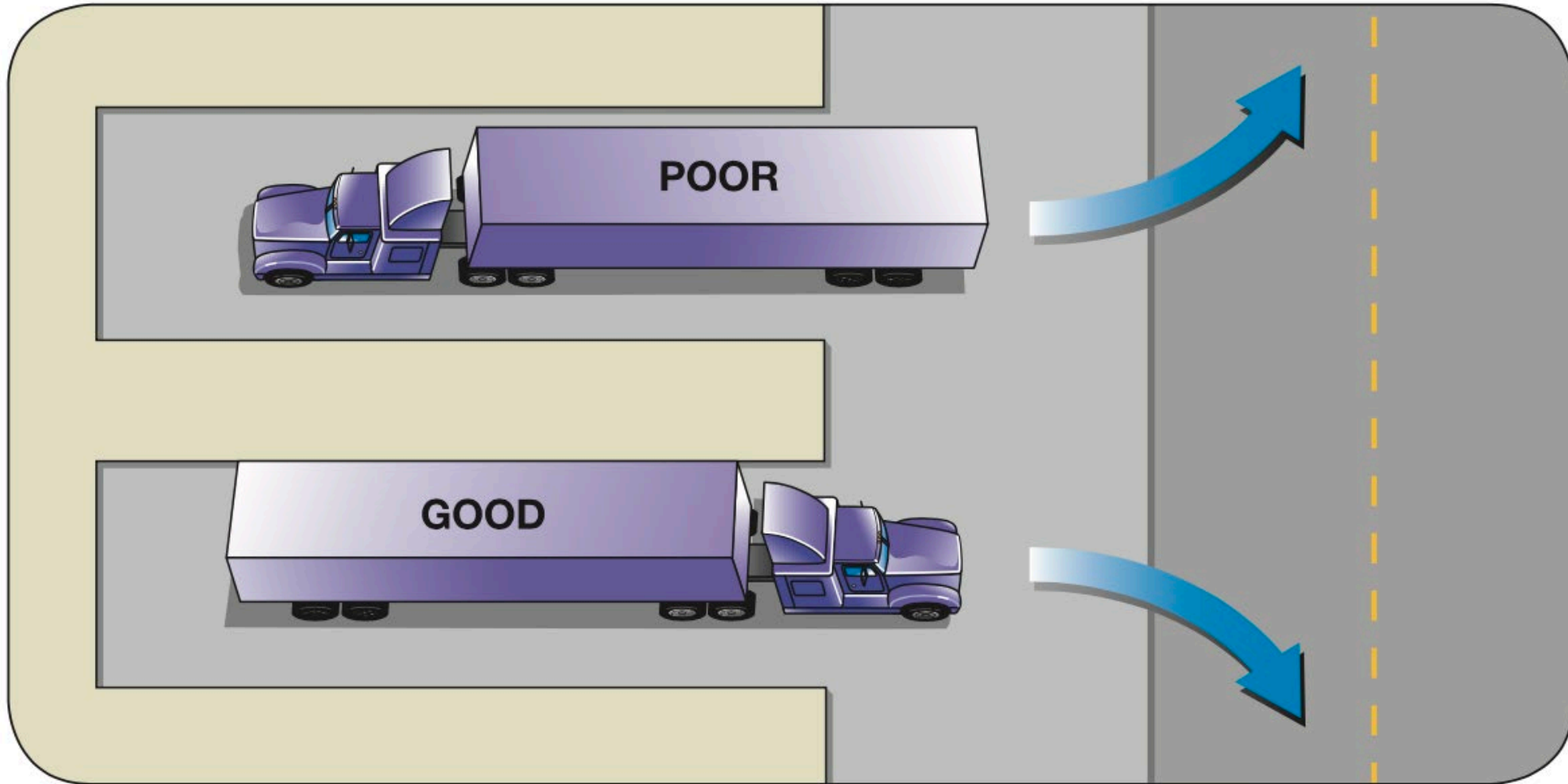

# Use a guide

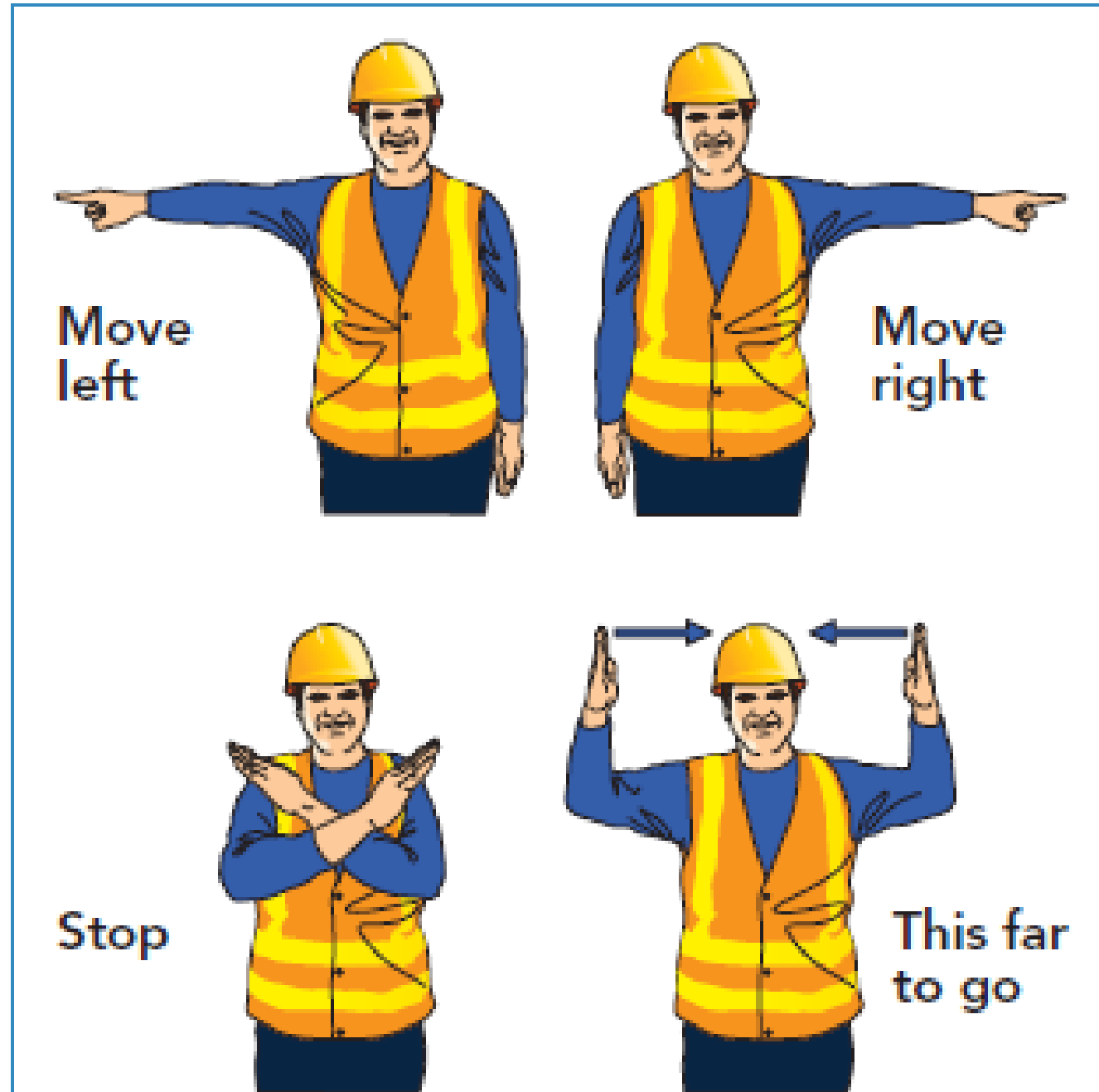

# Guide placement

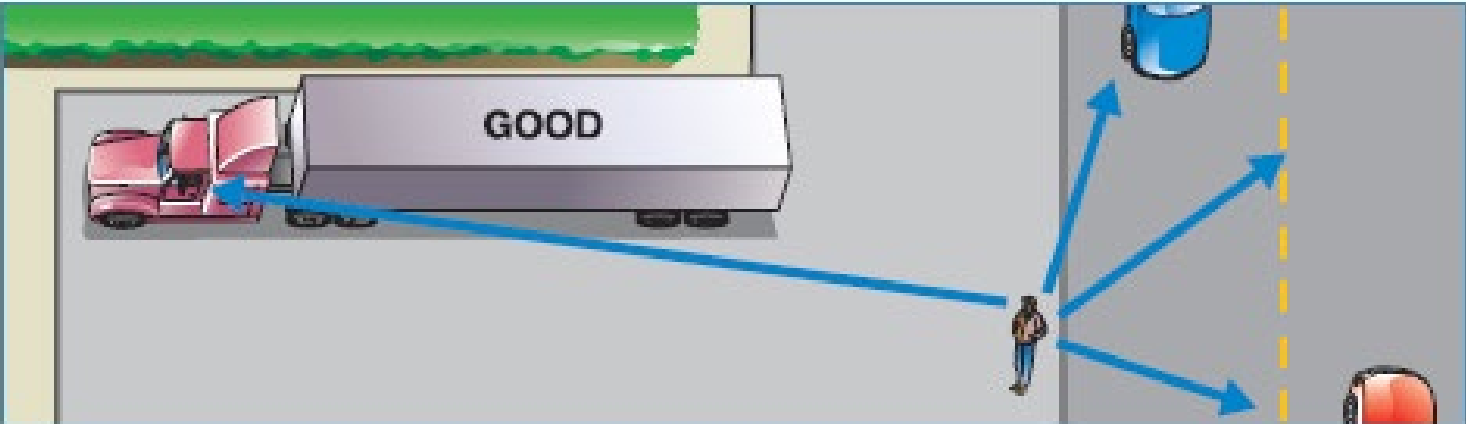

# Straight line backing

- The earlier a drift is detected, the less steering input will be needed to correct.
- It's easier to start over than to reposition the vehicle while backing.
- Use reference points.
- Check mirrors on both sides to help stay in a straight line.
- Honk twice when you start your backing and then again for every vehicle length as you proceed backwards.
- If you're backing to a loading dock, remember to open the trailer doors before you reach the building.

# Alley-Dock backing

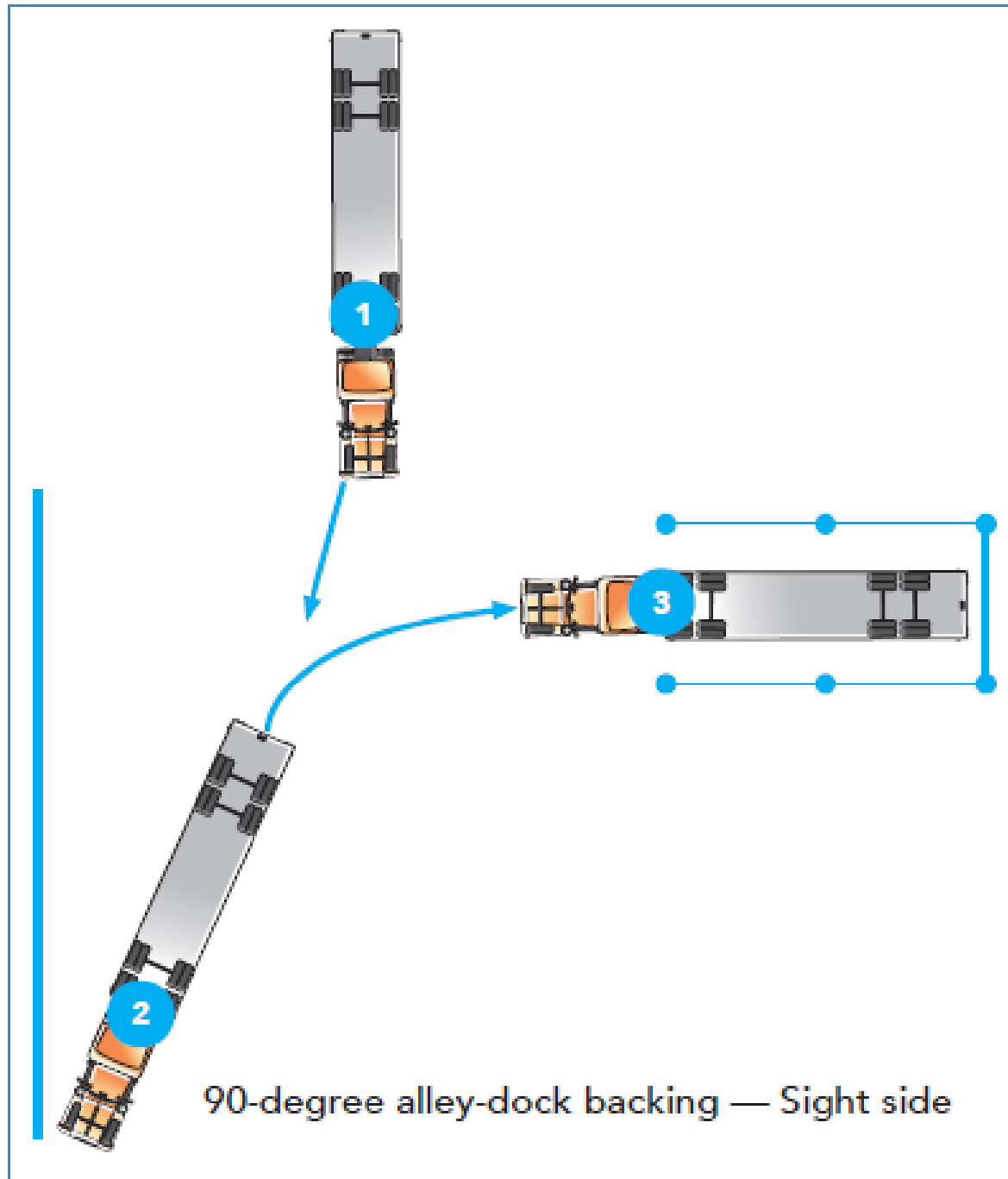



# Offset backing

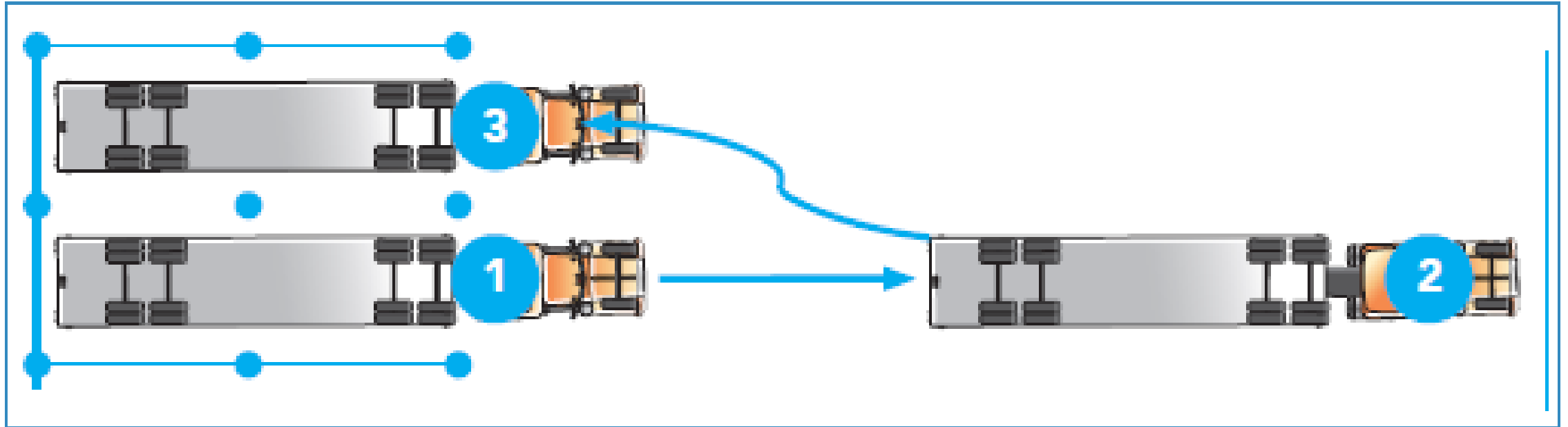

Offset backing (right and left) (5:14)

<https://www.youtube.com/watch?v=0u25cTDYEoQ>

# Parallel parking

YouTube Video

Parallel parking (1:53)

<https://www.youtube.com/watch?v=EHjK7ZWkDOI>